

Operating and Maintenance Instructions

Two Cycle Sno/Gard (Wet Bulb Primer)
Model Series 62000

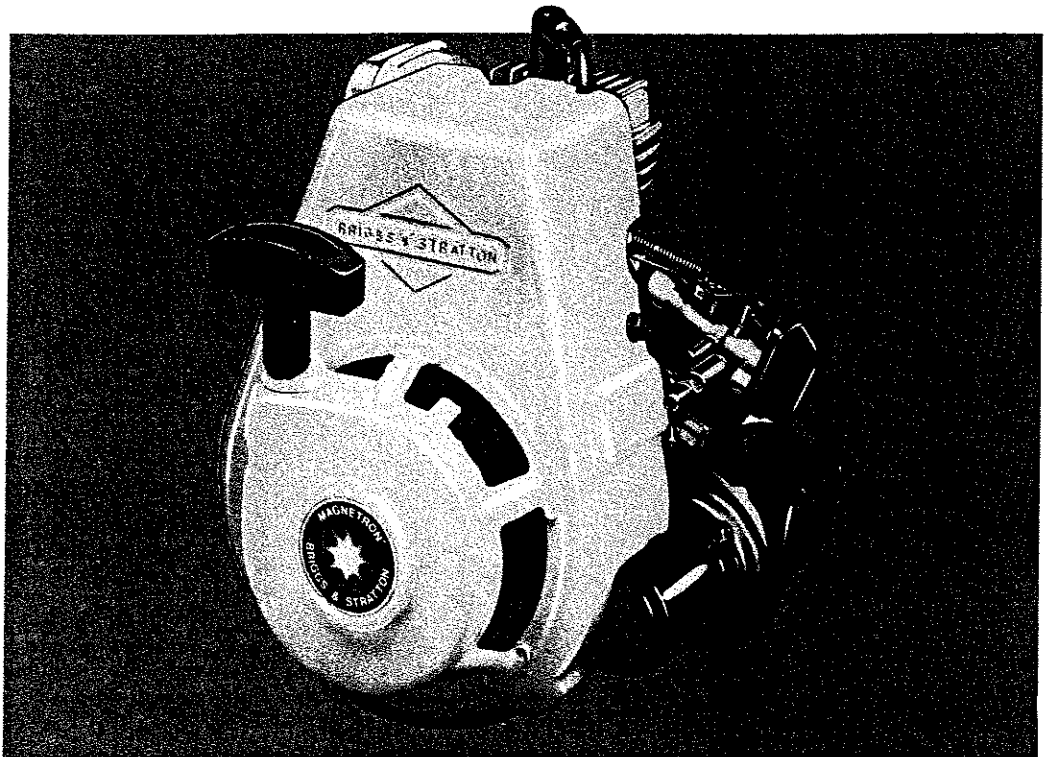

IMPORTANT SAFETY INFORMATION AND INSTRUCTIONS FOR ENGINE SELECTION ENGINE INSTALLATION ENGINE OPERATION

In the USA and Canada,
our 24 hour hotline is:

18002333723

Briggs & Stratton Corporation
Milwaukee, Wisconsin 53201

www.briggsandstratton.com

Keep these instructions for future reference.



Before installing and operating this engine read and observe all warnings, cautions and instructions on both sides of this sheet, on the engine, and in the operating & maintenance instructions.

NOTE: This sheet of instructions and safety information is not meant to cover all possible conditions and situations that may occur. Read entire Operating & Maintenance Instructions for this engine AND the instructions for the equipment this engine powers. Failure to follow instructions and safety information could result in serious injury or death.

The safety alert symbol () is used to identify safety information about hazards that can result in personal injury.

A signal word (DANGER, WARNING, or CAUTION) is used with the alert symbol to indicate the likelihood and the potential severity of injury. In addition, a hazard symbol may be used to represent the type of hazard.

 **DANGER** indicates a hazard which, if not avoided, will result in death or serious injury.

 **WARNING** indicates a hazard which, if not avoided, could result in death or serious injury.

 **CAUTION** indicates a hazard which, if not avoided, might result in minor or moderate injury.

CAUTION, when used **without** the alert symbol, indicates a situation that **could result in damage to the engine.**

HAZARD SYMBOLS AND MEANINGS



Fire



Explosion



Moving Parts



Toxic Fumes



Hot Surface



Shock



Kickback

(OVER)

FORM MS-6445-01/03

ENGINE SELECTION

 WARNING

Failure to select the correct engine could result in fire or explosion.

- Some engines are unique and designed for specific applications or types of equipment. If this engine will be used to build new equipment, contact Briggs & Stratton to ensure that the engine is appropriate for the intended use.
Note: For all Go-karts use only a model 136200 series engine, which offers improved safety and performance.
- Replacement engines should be the same model as the original engine, or be the Briggs & Stratton designated replacement engine. Refer to the Operation & Maintenance Instructions for engine identification information.
Note: For all Go-karts use only a model 136200 series engine, which offers improved safety and performance.
- Do not use Briggs & Stratton engines on 3-wheel All-Terrain Vehicles (ATVs), motor bikes, air craft products, or vehicles intended for use in competitive events. Briggs & Stratton does not approve of or authorize such uses.

ENGINE INSTALLATION

- [1] Do not attempt to install this engine if you do not have the appropriate tools and knowledge of small engine installation procedures. Use only Briggs & Stratton parts. Contact your Authorized Service Dealer for assistance.
- [2] Do not modify the engine in any way without Briggs & Stratton factory approval. Any such modification is at the owner's sole risk.
- [3] If the exhaust system on the old engine was supplied by the equipment manufacturer, you must transfer the exhaust system and related components (original muffler and related pipes, brackets, clamps, and shields) to the new engine. All components must be in good condition.
- [4]

 WARNING	Install muffler (and muffler deflector if used) so outlet points away from operator, fuel tank, and equipment, and so muffler heat will not damage or deform engine and components.
	
- [5]

 WARNING	Ensure all fuel lines and fittings are properly assembled and do not leak. Replacement parts must be the same model as the original.
	
- [6]

 WARNING	Ensure all wiring, including safety switches and engine shut-off components are completely installed and functioning properly.
	
- [7] Set engine speed to equipment manufacturer's specification. Refer to equipment manufacturer's manual. Do not tamper with governor springs, or other parts that will increase engine speed above specification.

- [8]







 WARNING	All engine parts, including fuel cap, spark plug, muffler, air cleaner, and covers and guards for drive components (gears, belts, shafts, couplings, etc.) must be in place before attempting to start engine.
	
- [9]

 WARNING	If engine is installed on walk behind lawn mower, all mower components, including cutting blade, must be correctly installed before attempting to start engine.
	
- [10]

 WARNING	When working on the engine or equipment, remove spark plug wire from spark plug. For electric start, remove negative wire from battery.
	
- [11]

 WARNING	Do not check for spark with spark plug removed. Use Briggs & Stratton spark tester #19368.
	

ENGINE OPERATION

	 WARNING
When adding fuel:	
Turn engine off and let engine cool at least 2 minutes before removing gas cap. Fill fuel tank outdoors or in well-ventilated area. Fill tank to about 1 inch below lowest portion of neck to allow for fuel expansion. Keep gasoline away from sparks, open flames, pilot lights, heat, and other ignition sources.	
	 WARNING
When starting engine:	
Remove all external equipment/engine loads. Wait until spilled fuel is evaporated. Start engine outdoors. Pull cord slowly until resistance is felt, then pull rapidly. If engine floods, set choke to OPEN/RUN, place throttle in FAST and crank until engine starts.	
	 WARNING
When operating equipment:	
Do not tip engine or equipment at angle which causes gasoline to spill. Run engine outdoors. Do not run in enclosed area, even if doors or windows are open. Do not choke carburetor to stop engine.	



IN THE INTEREST OF SAFETY



WARNING: DO NOT RUN THE ENGINE IN AN ENCLOSED AREA. Exhaust gases contain carbon monoxide, an odorless and deadly poison.

A FIRE OR EXPLOSION CAN OCCUR RESULTING IN PERSONAL INJURY IF THE FOLLOWING INSTRUCTIONS ARE NOT FOLLOWED:

1. DO NOT FILL GASOLINE TANK while engine is running. Allow engine to cool for two minutes before refueling.
2. Do not operate the engine when an odor of gasoline is present or other explosive conditions exist.
3. If gasoline is spilled, move machine away from the area of the spill and avoid creating any source of ignition until the gasoline has evaporated.
4. DO NOT STORE, SPILL OR USE GASOLINE NEAR AN OPEN FLAME, or devices such as a stove, furnace, water heater which utilize a pilot light, or devices which can create a spark.
5. Refuel outdoors preferably, or only in well ventilated areas.
6. DO NOT OPERATE ENGINE WITHOUT A MUFFLER. Inspect muffler periodically and replace, if necessary.
7. Periodically clean the muffler area to prevent grass, dirt and combustible material from accumulating.
8. DO NOT use this engine on any forest covered, brush covered or grass covered unimproved land unless a spark arrester is attached to the muffler.
9. DO NOT operate the engine if air cleaner or cover directly over the carburetor air intake is removed.
10. When transporting equipment which is powered by an engine using a float feed carburetor and a gravity feed fuel source, the fuel shut-off valve must be closed to prevent fuel leaking from carburetor.

CAUTION: DO NOT RUN ENGINE AT EXCESSIVE SPEEDS. Operating an engine at excessive speeds increases the danger of personal injury.

1. DO NOT TAMPER WITH GOVERNOR SPRINGS, GOVERNOR LINKS OR OTHER PARTS WHICH MAY INCREASE THE GOVERNED ENGINE SPEED.
2. Do not tamper with the engine speed selected by the original equipment manufacturer.
3. DO NOT TOUCH hot mufflers, cylinders or fins as contact may cause burns.
4. Dirt and grass clippings or other debris, in cooling fins or governor parts can affect engine speed. See cleaning instructions in MAINTENANCE section.
5. TO PREVENT HAND OR ARM INJURY, always pull starter cord rapidly to avoid kickback; starting engine with a loose blade or without a blade may cause a severe kickback.
6. ALWAYS KEEP HANDS AND FEET CLEAR OF MOVING OR ROTATING PARTS.
7. TO PREVENT ACCIDENTAL STARTING when servicing the engine or equipment, always remove the spark plug or wire from the spark plug and insert in holding tab, if so equipped, as shown in Instruction Manual.

WHEN WORKING ON EQUIPMENT

DO NOT STRIKE FLYWHEEL with a hard object or metal tool as this may cause flywheel to shatter in operation, causing personal injury or property damage. To remove flywheel, use Briggs & Stratton approved tools only.

IN THE INTEREST OF ENVIRONMENT

A muffler which leaks because of rust or damage can permit an increased exhaust noise level. Therefore, examine the muffler periodically to be sure it is functioning effectively. To purchase a new muffler, see SERVICE AND REPAIR INFORMATION.

CAUTION: If this engine is not equipped with a spark arrester and is to be used on any forest covered, brush covered, or grass covered unimproved land, before using on such land a spark arrester must be added to the muffler. The arrester must be maintained in effective working order by the operator. In the State of California the above is required by law (Section 4442 of the California Public Resources Code). Other states may have similar laws. Federal laws apply on federal lands. See your Authorized Briggs & Stratton Service Center for spark arrester muffler options.



THIS SYMBOL MEANS **WARNING** or **CAUTION**. PERSONAL INJURY AND/OR PROPERTY DAMAGE MAY OCCUR UNLESS INSTRUCTIONS ARE FOLLOWED CAREFULLY.

SERVICE & REPAIR INFORMATION

If service or repair is needed, contact an Authorized Briggs & Stratton Service Center. To serve you promptly and efficiently, the Service Center will need the model, type and code number on your engine.

Major engine repairs should not be attempted unless you have the proper tools and a thorough knowledge of internal combustion engine repair procedure.

Each Authorized Service Center carries a stock of original Briggs & Stratton repair parts and is equipped with special service tools. Trained mechanics assure expert repair service on all Briggs & Stratton engines.



Your nearest service center is listed in the "Yellow Pages" under "Engines, Gasoline" or "Gasoline Engines." He is one of over 25,000 authorized dealers available to serve you.

GENERAL INFORMATION

This engine is a single-cylinder air-cooled type.

MODEL SERIES 62000

Bore..... 2-1/8" (53.98 mm)
 Stroke 1-3/4" (44.45 mm)
 Displacement 6.21 cu. in. (102.0 cc)
 Horsepower Max. 3.0 @ 4200 RPM
 Torque (Ft. Lbs.) Max. 3.85 @ 3300 RPM

The horsepower rating listed above is established in accordance with the Society of Automotive Engineers Test Code-J607. For practical operation, the horsepower loading should not exceed 85% of this rating. Engine power will decrease 3-1/2% for each 1,000 feet (304.8 m) above sea level and 1% for each 10° above 60° F (16° C).

In some areas, local law requires the use of a resistor spark plug so as to suppress ignition signals. If an engine was originally equipped with a resistor spark plug, be sure to use the same type of spark plug for replacement.

TUNE-UP SPECIFICATIONS

Spark Plug Type	Champion	Autolite
Short Plug	CJ-8	235
Resistor Short Plug	RCJ-8	245

Spark Plug Gap030" (.76 mm)

STORAGE INSTRUCTIONS

Engines to be stored over 30 days should be completely drained of fuel to prevent gum deposits forming on essential carburetor parts, fuel filter and tank.

NOTE: The use of a fuel additive, such as STA-BIL®, or an equivalent, will minimize the formation of fuel gum deposits during storage. Such an additive may be added to the gasoline in the fuel tank of the engine, or to the gasoline in a storage container.

- All fuel should be removed from the tank. Run the engine until it slows, then place choke in "ON" position. Let engine run until it stops from lack of fuel.
- Remove spark plug, pour approximately 1/2 ounce (15 cc) of engine oil into cylinder and crank slowly to distribute oil. Replace spark plug.
- Store in a clean and dry area.

BRIGGS & STRATTON ENGINES ARE MADE UNDER ONE OR MORE OF THE FOLLOWING PATENTS:

2,999,491	3,305,223	3,526,146	3,625,492	3,745,393	3,971,353	4,233,043
3,194,224	3,457,804	3,572,218	3,650,354	3,961,724	4,168,288	4,270,509
3,276,439	3,465,740	3,625,071	3,738,345	3,968,854	4,189,040	

DESIGN
 D-247,177
 OTHER PATENTS PENDING

BEFORE STARTING

**THIS IS A 2 CYCLE ENGINE AND
REQUIRES MIXING OF GASOLINE AND OIL**

FUEL/OIL MIXTURE

Use a high quality BIA certified 2 cycle oil rated TC-W.

DO NOT USE AUTOMOTIVE OIL.

Our engines will operate satisfactorily on any gasoline intended for automotive use.

We recommend the use of clean, fresh, winter grade, lead-free gasoline. Leaded gasoline may be used if lead-free is not available. A minimum of 77 octane is recommended. The use of lead-free gasoline results in fewer combustion deposits.

NOTE: We **DO NOT** recommend the use of gasoline which contains alcohol, such as gasohol. However, if gasoline with alcohol is used, it **MUST NOT** contain more than 10 percent Ethanol and **MUST** be removed from the engine during storage. **DO NOT** use gasoline containing Methanol. See **STORAGE INSTRUCTIONS**.

DO NOT use gasoline left over from summer lawn-mower use.

DO NOT fill tank to point of overflowing. Allow tank space for fuel expansion.

INITIAL START ONLY: For proper break-in, the first tank of fuel must have a gasoline to oil ratio of 16:1. In a separate container, thoroughly mix 8 ounces (0.25 liters) of oil with 1 gallon (3.79 liters) of gasoline.

After break-in, the gasoline to oil ratio is 32:1. In a separate container, thoroughly mix 4 ounces (0.125 liters) of oil with 1 gallon (3.79 liters) of gasoline.

CAUTION: Observe recommended gasoline to oil mixing ratio to prevent engine damage.

FUEL/OIL MIXTURE CHART

U.S.		Imperial		Metric	
Gasoline Gallons	2 Cycle Oil Ounces	Gasoline Gallons	2 Cycle Oil Ounces	Gasoline Liters	2 Cycle Oil Liters
1 (Break-In)	8 (Break-In)	1 (Break-In)	9 (Break-In)	4 (Break-In)	0.25 (Break-In)
1	4	1	4.5	4	0.125
2	8	2	9	8	0.25
5	20	5	22.5	20	0.625

To assure thorough mixing of oil and gasoline:

- fill container partially with gasoline.
- add oil per chart.
- shake container vigorously.
- add remainder of gasoline into container and shake vigorously.

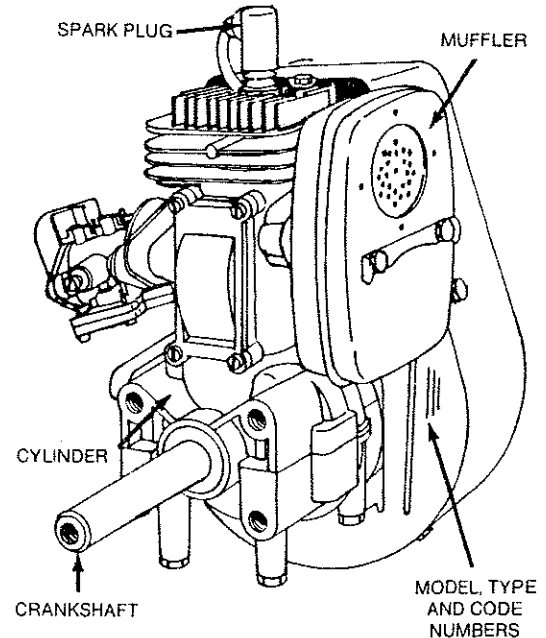
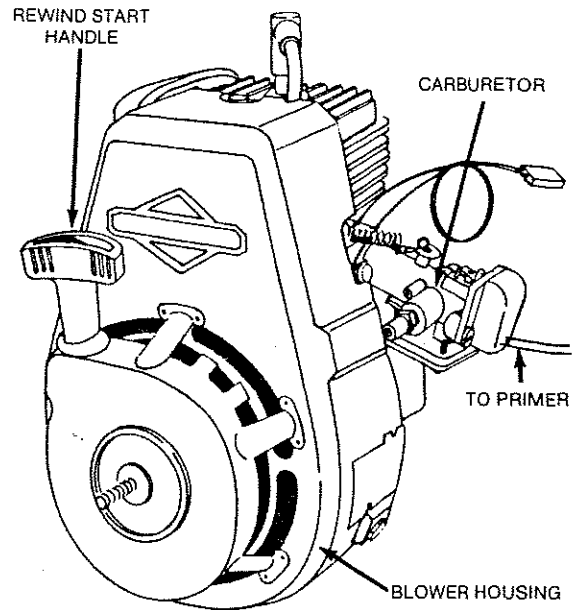

STARTING

READ THE OPERATING INSTRUCTIONS OF THE EQUIPMENT THIS ENGINE POWERS

TO START A NEW OR STORED ENGINE

WARNING: ALWAYS KEEP HANDS AND FEET CLEAR OF SNOW AUGER OR OTHER ROTATING MACHINERY.

1. Pull choke out as illustrated.

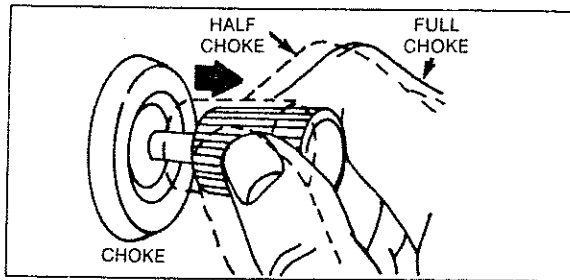

2. To prime:

When engine is new (out of the carton) or has been stored over the summer, prime as follows:

PRESS PRIMER UNTIL BULB IS FIRM TO FILL SYSTEM WITH FUEL. (Approximately 15 to 25 primes may be required for new engines.) Then prime as described below.

3. a. To prime a cold engine:

Above 0°F (-18°C) - Prime ONCE
Below 0°F (-18°C) - Prime TWICE

NOTE: If engine does not start after four pulls with rewind starter or five seconds of cranking with electric starter, prime once more.

- b. To prime a warm engine:

A warm engine usually does not require priming.

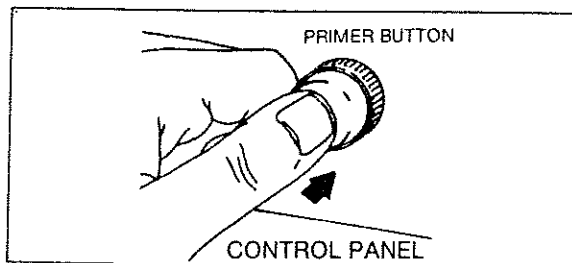

NOTE: Overpriming will cause engine flooding. If flooding occurs, push choke knob completely IN. Actuate starter until engine starts.

4. Turn KEY to RUN position, if so equipped.

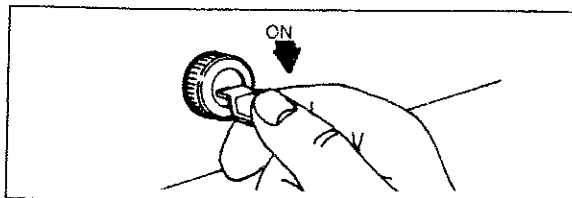

5. Rewind Start. Grasp grip as illustrated and pull slowly until starter engages. Then pull starter grip rapidly to prevent kickback and start engine. When engine starts, push choke in gradually as engine warms up.

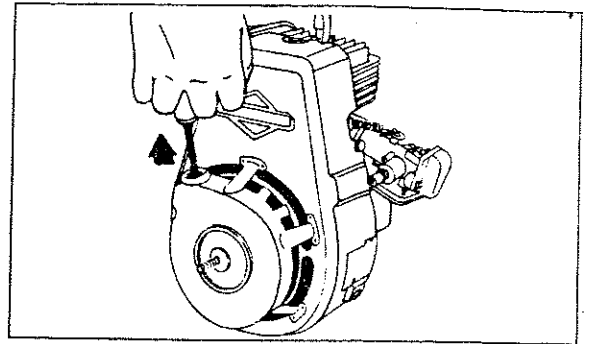

6. Electric Start (Optional). Turn key to "START" position on powered equipment. Push starter button if so equipped. The best starter life is provided by using short starting cycles of several seconds. Prolonged cranking can damage the starter motor if cranked more than 15 seconds per minute. When engine starts, push choke in gradually as engine warms up. (Rewind starter may be used if engine cannot be started electrically.)

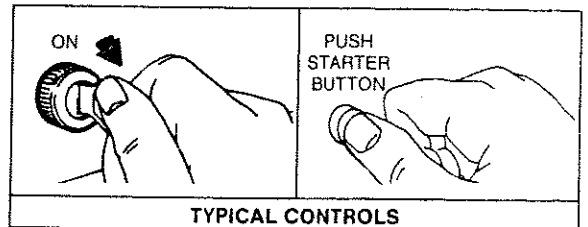

CAUTION: The 120 volt electric starter is equipped with a three-prong plug for your safety. The longer prong in this plug is connected to the starter motor housing. When the starter motor is plugged into the three-wire cord supplied, and the cord is plugged into a properly grounded receptacle, it will protect the user from shock should the starter motor insulation fail for any reason. If a longer extension cord is used with this starter, it should also have three-prong and three-hole plugs.

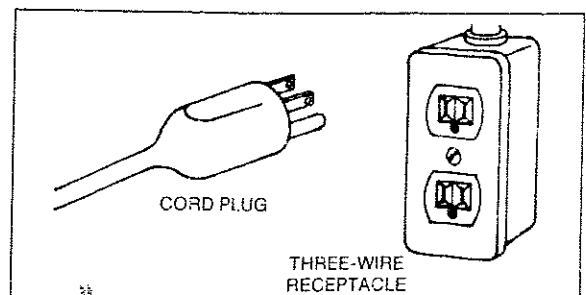

STARTING (Cont.)

COLD WEATHER STARTING HINTS

1. Start in a cleared area.
2. Use fresh winter grade fuel.
3. Using a separate container, mix gasoline and oil in correct proportion (32:1). (16:1/Break-In).
4. Prime carburetor correctly for starting temperature.
5. Use short starting cycles (15 seconds per minute, electric starter).
6. A slightly richer fuel mixture, obtained by turning carburetor needle valve 1/8 turn counterclockwise may improve cold starting.

TO STOP ENGINE

Turn key to "STOP" or "OFF" position.

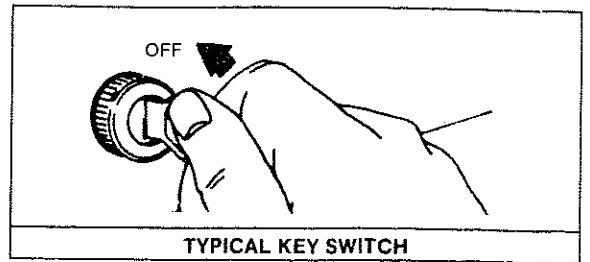

CAUTION: Always remove key from switch when leaving equipment unattended or when equipment is not in use.

NOTE: After using snow removal equipment, continue to run the engine for about five minutes in an area protected from snow. This will give the engine an opportunity to dry out any moisture which has collected.

When equipment is not in operation, provide protection from direct exposure to freezing rain and snow.

MAINTENANCE

CAUTION: TO PREVENT ACCIDENTAL STARTING when servicing the engine or equipment, always remove the spark plug or wire from the spark plug.

SPARK PLUG — Clean and reset gap at .030" every season.

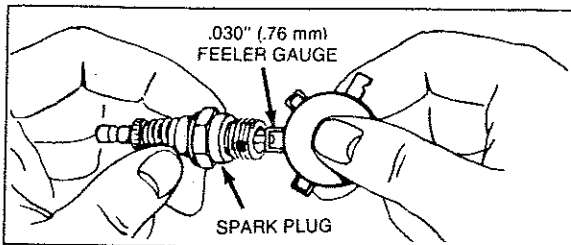

NOTE: Do not blast clean spark plug. Spark plug should be cleaned by scraping or wire brushing and washing with a commercial solvent.

CAUTION: Sparking can occur if wire terminal does not fit firmly on spark plug. Reform terminal if necessary.

FUEL FILTER — Replace IN-LINE filter every season.

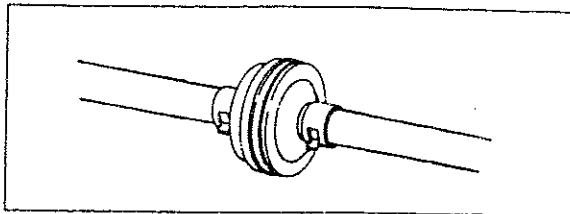

RECOMMENDED

Occasionally place a few drops of oil on governor and throttle linkage and choke. A slight film of oil on these parts will afford additional protection from freezing and corrosion.

SNO/GARD engines are designed for operation in a dust-free atmosphere, under cold weather conditions. Do not operate under dusty conditions, or for an extended period under warm weather conditions (50°F/10°C).

ADJUSTMENTS

CARBURETOR ADJUSTMENTS

Minor carburetor adjustment may be required to compensate for differences in fuel, temperature, altitude or load.

Carburetor adjustments should be made at same temperature in which operation is expected.

TO ADJUST CARBURETOR — Gently turn needle valve clockwise until it just closes. Valve may be damaged by turning it too far.

Now open needle valve 1-1/2 turns counterclockwise. This initial adjustment will permit the engine to be started and warmed up (approximately five minutes) prior to final adjustment.

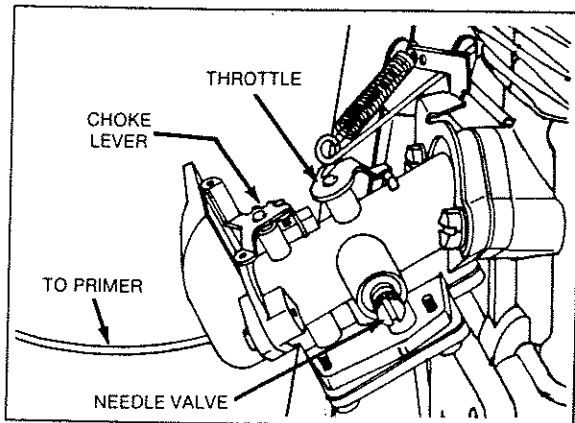

FINAL ADJUSTMENT

Turn needle valve slowly clockwise (lean) until engine runs smoothly. Now turn needle valve slowly counterclockwise (rich) until engine starts to sputter. This position will provide the best performance.

CAUTION: Needle valve must NEVER be adjusted leaner than 1-1/4 turns open.

CONTROL ADJUSTMENTS:

TO ADJUST MANUAL CHOKE:

Place remote control lever on equipment in "CHOKE" position. Loosen control casing clamp screw. Move casing and wire in direction shown by arrow to place choke plate in carburetor in full choke position. Tighten casing clamp screw.

