

DO NOT REMOVE SAMPLE

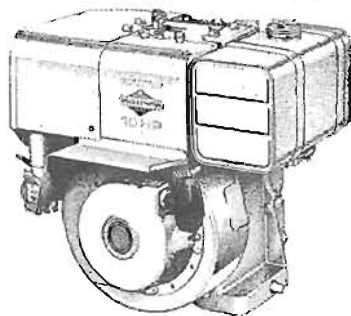

Briggs & Stratton

**OPERATING AND MAINTENANCE INSTRUCTIONS**

**SNO/GARD MODELS  
251400 to 251499**

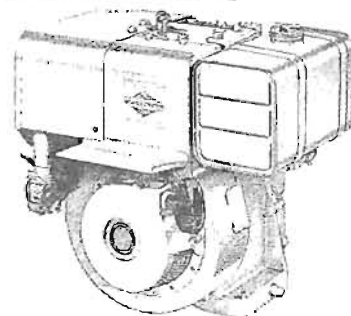

**IN THE INTEREST OF SAFETY**

DO NOT RUN ENGINE AT EXCESSIVE SPEEDS. Operating an engine at excessive speeds increases the hazard of personal injury. DO NOT TAMPER WITH PARTS WHICH MAY INCREASE THE GOVERNED SPEED.

DANGER: GASOLINE VAPOR IS HIGHLY FLAMABLE. Refuel outdoors preferable, or only in well ventilated areas.

DO NOT STORE, SPILL OR USE GASOLINE NEAR AN OPEN FLAME or devices such as a stove, furnace, water heater which utilize a pilot light, or devices that can create a spark. If gasoline is accidentally spilled, move machine away from area of spill and avoid creating any source of ignition until gasoline vapors have dissipated.

DO NOT REFUEL GASOLINE TANK WHILE ENGINE IS RUNNING.

DO NOT RUN THE ENGINE IN AN ENCLOSED AREA. Exhaust gases contain carbon monoxide, an odorless and deadly poison. TO PREVENT ACCIDENTAL STARTING always remove the spark plug from the engine before working on the engine or equipment driven by the engine.

ALWAYS KEEP HANDS AND FEET CLEAR OF ROTATING PARTS.

SNO/GARD engines are designed for operation in a dust free atmosphere, under cold weather conditions. Do not operate under dusty conditions, or for an extended period under warm weather conditions.

**IN THE INTEREST OF ENVIRONMENT**

A muffler which leaks because of rust or damage can permit an increased exhaust noise level. Therefore, examine the muffler periodically to be sure it is functioning effectively. To purchase a new muffler, see SERVICE AND REPAIR INFORMATION.

---

## SERVICE & REPAIR INFORMATION

---

Major engine repairs should not be attempted unless you have the proper tools and a thorough knowledge of internal combustion engine repair procedure.

If service or repair is needed, contact an Authorized Briggs & Stratton Service Center. To serve you promptly and efficiently, the Service Center will need the model, type and code number on your engine.

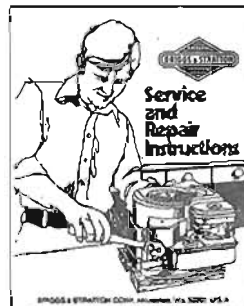

Your nearest service center is listed in the 'Yellow Pages' under "Engines, Gasoline" or "Gasoline Engines". He is one of over 21,000 authorized dealers available to serve you.

This illustrated book includes "Theories of Operation", common specifications, and detailed information covering the adjustment, tune-up and repair procedures for 2 through 16 H.P. models. It is available from any Authorized Briggs & Stratton Service Center. Order as Part Number 270962.



# IMPORTANT SAFETY INFORMATION AND INSTRUCTIONS FOR ENGINE SELECTION ENGINE INSTALLATION ENGINE OPERATION

In the USA and Canada,  
our 24 hour hotline is:

18002333723

Briggs & Stratton Corporation  
Milwaukee, Wisconsin 53201

[www.briggsandstratton.com](http://www.briggsandstratton.com)

Keep these instructions for future reference.



**Before installing and operating this engine read and observe all warnings, cautions and instructions on both sides of this sheet, on the engine, and in the operating & maintenance instructions.**

**NOTE:** This sheet of instructions and safety information is not meant to cover all possible conditions and situations that may occur. Read entire Operating & Maintenance Instructions for this engine AND the instructions for the equipment this engine powers. Failure to follow instructions and safety information could result in serious injury or death.

The safety alert symbol () is used to identify safety information about hazards that can result in personal injury.

A signal word (DANGER, WARNING, or CAUTION) is used with the alert symbol to indicate the likelihood and the potential severity of injury. In addition, a hazard symbol may be used to represent the type of hazard.

 **DANGER** indicates a hazard which, if not avoided, will result in death or serious injury.

 **WARNING** indicates a hazard which, if not avoided, could result in death or serious injury.

 **CAUTION** indicates a hazard which, if not avoided, might result in minor or moderate injury.

**CAUTION**, when used **without** the alert symbol, indicates a situation that **could result in damage to the engine.**

## HAZARD SYMBOLS AND MEANINGS



Fire



Explosion



Moving Parts



Toxic Fumes



Hot Surface



Shock



Kickback

(OVER)

FORM MS-6445-01/03

# ENGINE SELECTION

 <b>WARNING</b>

<b>Failure to select the correct engine could result in fire or explosion.</b>

- Some engines are unique and designed for specific applications or types of equipment. If this engine will be used to build new equipment, contact Briggs & Stratton to ensure that the engine is appropriate for the intended use.  
**Note: For all Go-karts use only a model 136200 series engine, which offers improved safety and performance.**
- Replacement engines should be the same model as the original engine, or be the Briggs & Stratton designated replacement engine. Refer to the Operation & Maintenance Instructions for engine identification information.  
**Note: For all Go-karts use only a model 136200 series engine, which offers improved safety and performance.**
- Do not use Briggs & Stratton engines on 3-wheel All-Terrain Vehicles (ATVs), motor bikes, air craft products, or vehicles intended for use in competitive events. Briggs & Stratton does not approve of or authorize such uses.

# ENGINE INSTALLATION

- [1] Do not attempt to install this engine if you do not have the appropriate tools and knowledge of small engine installation procedures. Use only Briggs & Stratton parts. Contact your Authorized Service Dealer for assistance.
- [2] Do not modify the engine in any way without Briggs & Stratton factory approval. Any such modification is at the owner's sole risk.
- [3] If the exhaust system on the old engine was supplied by the equipment manufacturer, you must transfer the exhaust system and related components (original muffler and related pipes, brackets, clamps, and shields) to the new engine. All components must be in good condition.
- [4] 

 <b>WARNING</b>	Install muffler (and muffler deflector if used) so outlet points away from operator, fuel tank, and equipment, and so muffler heat will not damage or deform engine and components.
	
- [5] 

 <b>WARNING</b>	Ensure all fuel lines and fittings are properly assembled and do not leak. Replacement parts must be the same model as the original.
	
- [6] 

 <b>WARNING</b>	Ensure all wiring, including safety switches and engine shut-off components are completely installed and functioning properly.
	
- [7] Set engine speed to equipment manufacturer's specification. Refer to equipment manufacturer's manual. Do not tamper with governor springs, or other parts that will increase engine speed above specification.

- [8] 







 <b>WARNING</b>	All engine parts, including fuel cap, spark plug, muffler, air cleaner, and covers and guards for drive components (gears, belts, shafts, couplings, etc.) must be in place before attempting to start engine.
	
- [9] 

 <b>WARNING</b>	If engine is installed on walk behind lawn mower, all mower components, including cutting blade, must be correctly installed before attempting to start engine.
	
- [10] 

 <b>WARNING</b>	When working on the engine or equipment, remove spark plug wire from spark plug. For electric start, remove negative wire from battery.
	
- [11] 

 <b>WARNING</b>	Do not check for spark with spark plug removed. Use Briggs & Stratton spark tester #19368.
	

# ENGINE OPERATION

	 <b>WARNING</b>
<b>When adding fuel:</b>	
Turn engine off and let engine cool at least 2 minutes before removing gas cap. Fill fuel tank outdoors or in well-ventilated area. Fill tank to about 1 inch below lowest portion of neck to allow for fuel expansion. Keep gasoline away from sparks, open flames, pilot lights, heat, and other ignition sources.	
	 <b>WARNING</b>
<b>When starting engine:</b>	
Remove all external equipment/engine loads. Wait until spilled fuel is evaporated. Start engine outdoors. Pull cord slowly until resistance is felt, then pull rapidly. If engine floods, set choke to OPEN/RUN, place throttle in FAST and crank until engine starts.	
	 <b>WARNING</b>
<b>When operating equipment:</b>	
Do not tip engine or equipment at angle which causes gasoline to spill. Run engine outdoors. Do not run in enclosed area, even if doors or windows are open. Do not choke carburetor to stop engine.	

# BEFORE STARTING

## READ THE OPERATING INSTRUCTIONS OF THE EQUIPMENT THIS ENGINE POWERS

This Briggs & Stratton winterized "Sno/Gard" engine is protected by a unique weather-shield system that guards all critical engine parts and greatly adds to ease of starting and dependability of operation under extreme cold weather conditions.

Use a high quality detergent oil classified "For Service SC, SD, SE or MS". Detergent oils keep the engine cleaner and retard the formation of gum and varnish deposits. Nothing should be added to the recommended oil.

### OIL RECOMMENDATIONS

**WINTER**  
(Under 40° F.)  
Use SAE 5W-20 or SAE 5W-30

If not available,  
Use SAE 10W or SAE 10W-30

(Below 0° F.)  
Use SAE 10W or SAE 10W-30  
Diluted 10% with Kerosene

**FILL CRANKCASE WITH OIL.** Place engine level. Clean area around oil fill tube before removing dipstick. Remove cap and dipstick and fill to full mark on dipstick. **POUR SLOWLY.** Capacity 3 pints. (1.4 Liters) When checking oil level, push dipstick assembly firmly but slowly until cap bottoms on tube. Do not overfill. Dipstick assembly must be pushed fully into tube at all times when engine is operating.

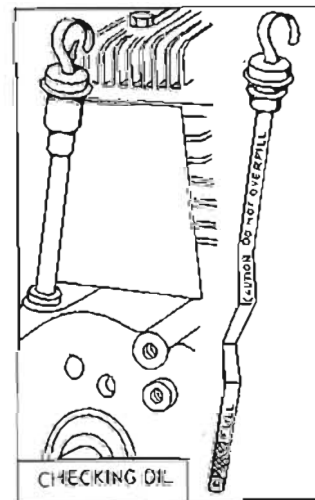
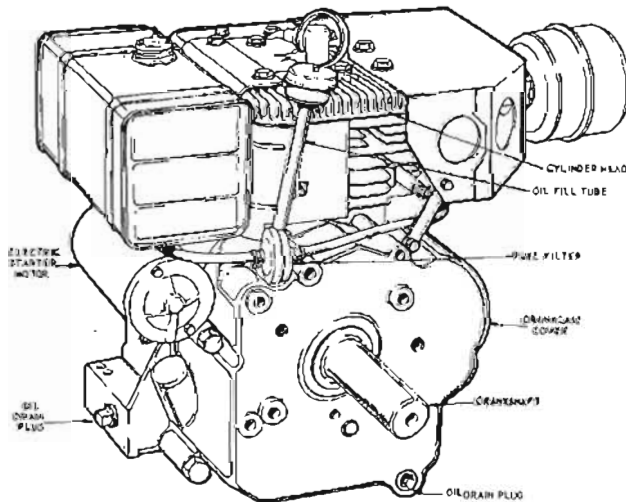
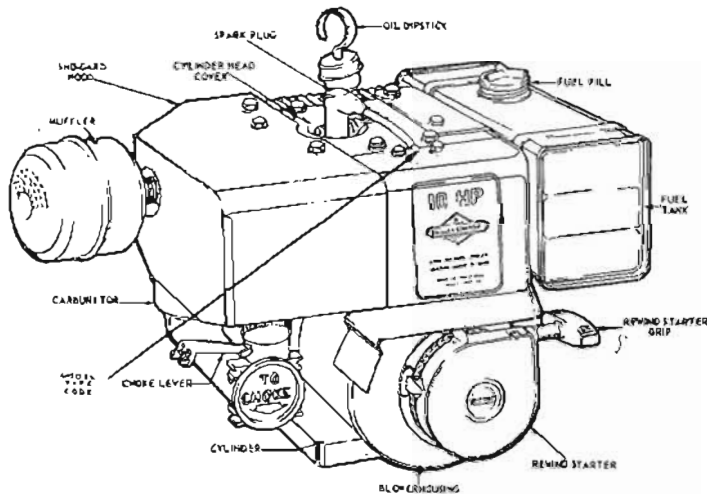

**FILL FUEL TANK.** Use clean, fresh, lead-free, or leaded "regular" gasoline. **DO NOT MIX WITH GASOLINE.**

Winter grade gasoline has higher volatility to improve starting. Do not use gasoline left over from summer.

# STARTING

## OPEN FUEL VALVE

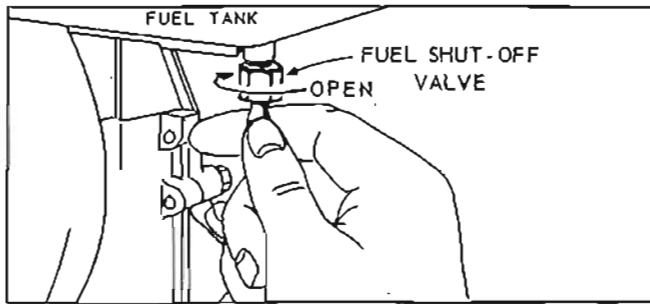

## CHOKE THE CARBURETOR

Move lever in direction of arrow to fully closed choke position.

NOTE: A warm engine requires less choking than a cold engine.

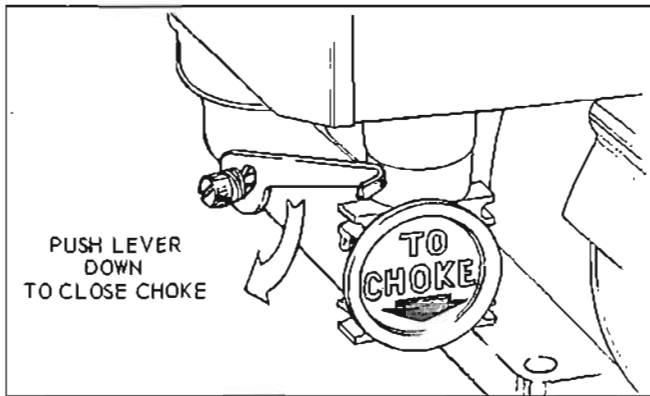

Move governor throttle control to "Run" or "Fast" position.

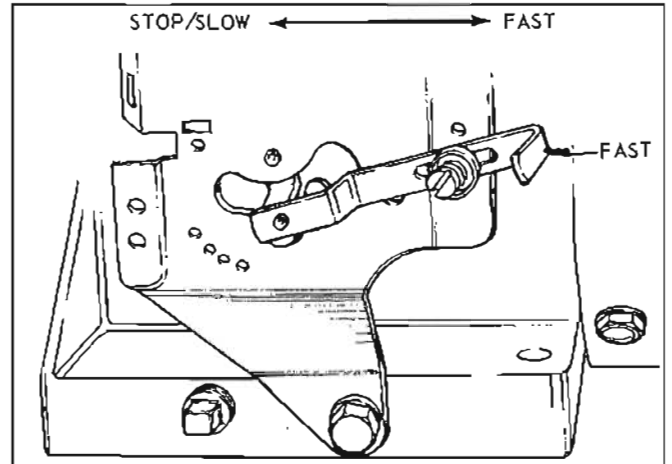
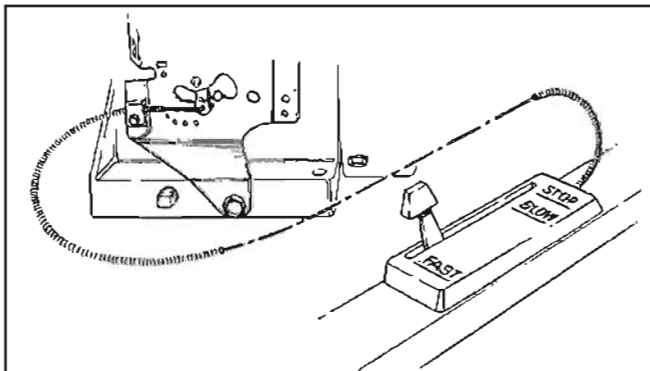

**ALWAYS KEEP HANDS AND FEET CLEAR OF ROTATING MACHINERY.**

## START ENGINE

- Rewind Starter. Grasp starter grip as illustrated and pull out cord rapidly. Repeat if necessary. When engine starts, open choke gradually.

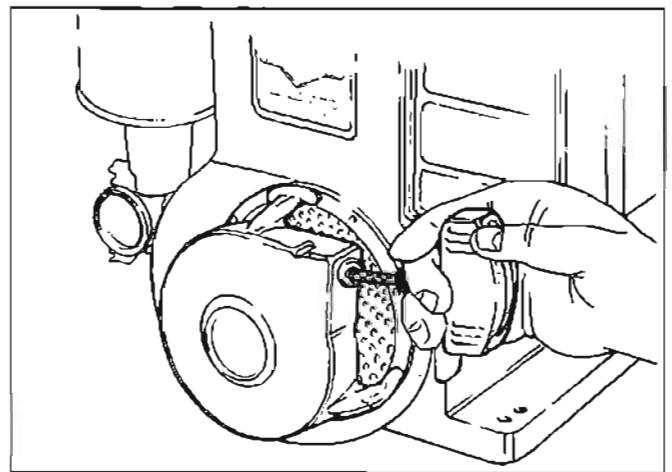

b. Electric Starter (Optional). Turn key or press starter button. When engine starts, open choke gradually.

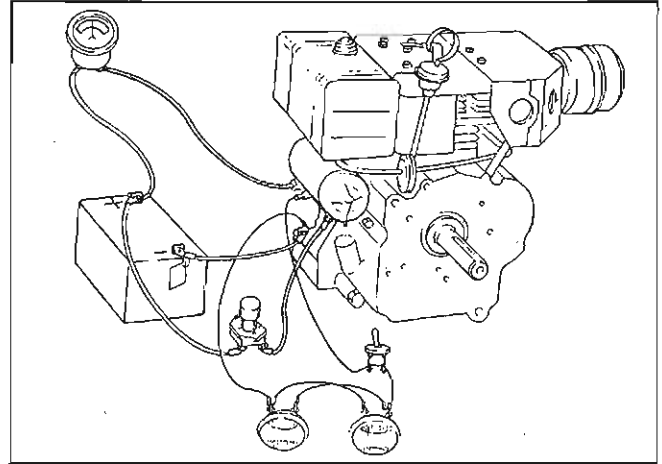
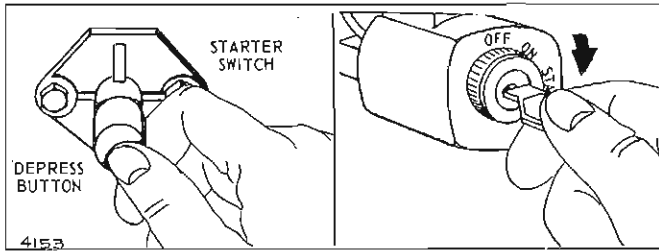

**CAUTION:** The 110 volt electric starter is equipped with a three-prong plug for your safety. The longer prong in this plug is connected to the starter motor housing. When the starter motor is plugged into the three wire cord supplied, and the cord is plugged into a properly grounded receptacle, it will protect the user from shock should the starter motor insulation fail for any reason. If a longer extension cord is used with this starter it should also have three-prong and three-hole plugs.

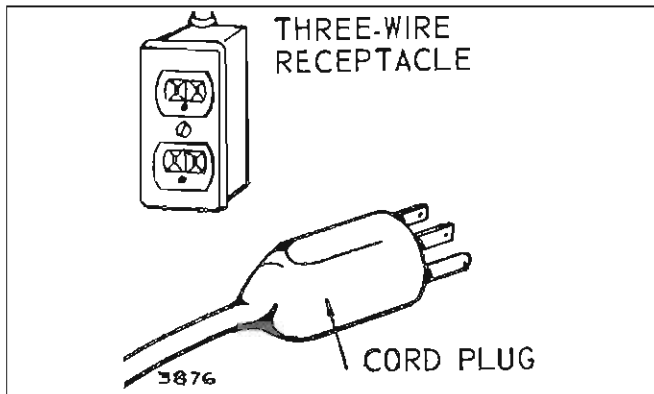

**WARNING:** For electrical safety, always remove cable from negative (-) side of the battery before attempting any repairs or maintenance.

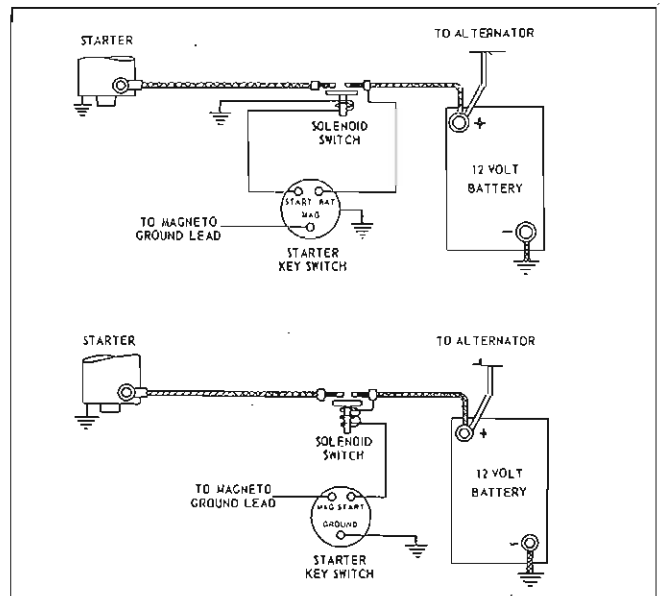

#### COLD STARTING HINTS

1. Be sure to use the proper oil for the temperature expected.
2. Declutch all possible external loads.
3. Set throttle at part-throttle position.
4. A slightly richer fuel mixture, obtained by turning carburetor needle valve 1/8 turn counterclockwise will usually improve cold starting.
5. A warm battery has much more starting capacity than a cold battery.
6. Use fresh winter grade fuel.

**NOTE:** If fuel drips out of carburetor while trying to start engine, the engine is over chocked. Pull rewind starter handle several times, or engage electric starter switch and crank engine with choke open.

**TO STOP ENGINE** move engine speed control to "STOP" position or turn key to "OFF" position.

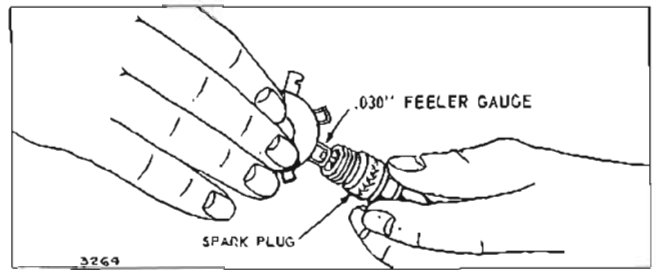
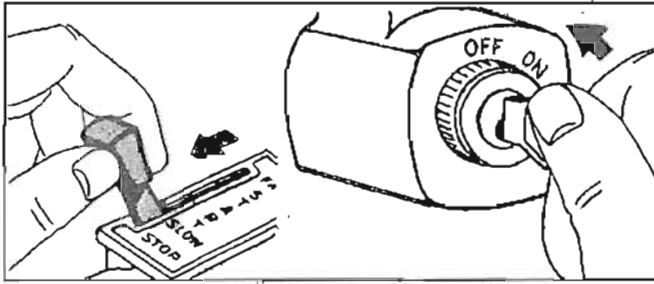

## MAINTENANCE

**CHECK OIL LEVEL** regularly — after each 5 hours of operation. **BE SURE OIL LEVEL IS MAINTAINED TO FULL MARK ON DIPSTICK.** CHANGE OIL after first 5 hours of operation. Thereafter change oil every 25 hours of operation. Remove oil drain plug and drain oil while engine is warm. Replace drain plug. Remove dipstick and refill with new oil of proper grade. Replace dipstick.

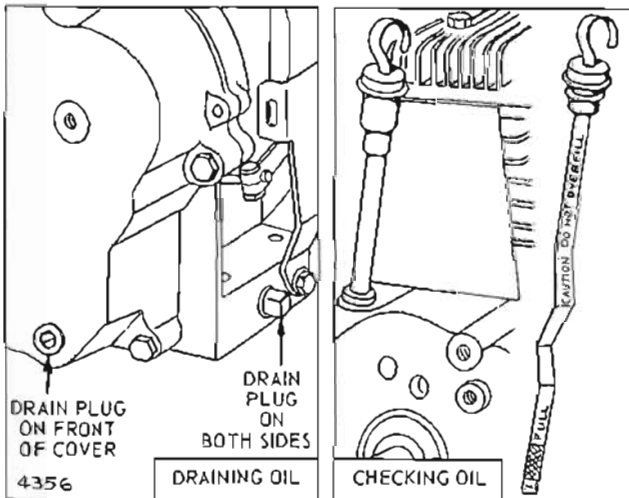

**SPARK PLUG:** Clean and reset gap at .030" every 100 hours of operation.

**CAUTION:** Do not blast clean spark plugs. Spark plugs should be cleaned by scraping or wire brushing and washing with a commercial solvent.

**REMOVE CARBON DEPOSITS:** Clean combustion chamber, top of piston and around both valves every 100-300 hours of operation.

### RECOMMENDED

Occasionally place a few drops of oil on governor and throttle linkage and choke. A slight film of oil on these parts will afford additional protection from freezing and corrosion. After using snow removal equipment, continue to run the engine for about 10 minutes in an area protected from snow. This will give the engine an opportunity to dry out any moisture which has collected. When equipment is not in operation, provide protection from direct exposure to freezing rain or snow.

## ADJUSTMENTS

### CARBURETOR ADJUSTMENTS

Carburetors are adjusted at the factory and normally do not need adjustment unless they have been dis-assembled.

Initial adjustment after re-assembly.

Turn needle valve clockwise until it just closes.

**CAUTION:** Valve may be damaged by turning it in too far.

Now open needle valve 1½ turn counter-clockwise.

Close idle valve in same manner and open 1 turn. This initial adjustment will permit the engine to be started and warmed up prior to final adjustment.

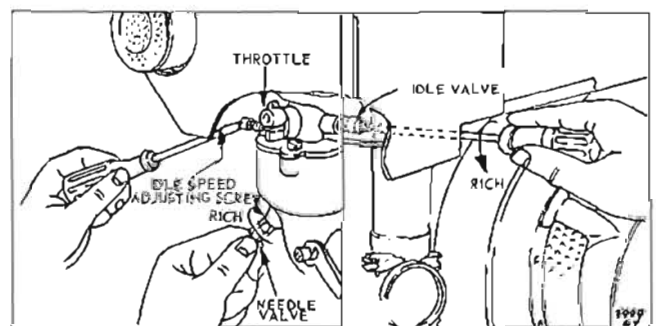

## FINAL ADJUSTMENT

With governor throttle control in "FAST" position, turn needle valve in until engine misses (lean mixture) then turn it out past smooth operating point until engine runs unevenly (rich mixture). Now turn needle valve to the mid-point between rich and lean so the engine runs smoothly. Hold throttle at idle position and set idle speed adjusting screw until fast idle is obtained (1750 RPM). Hold throttle in idle position and turn idle valve in (lean) and out (rich) until engine idles smoothly. Then reset idle speed adjusting screw so that engine idles at 1750 RPM. Release throttle — engine should accelerate without hesitation or sputtering. If engine does not accelerate properly, the carburetor should usually be re-adjusted to a slightly richer mixture.

## REMOTE CONTROL:

Proper maximum speed and "STOP" switch operation is dependent upon proper adjustment of remote control on the powered equipment.

## TO ADJUST REMOTE CONTROL:

Place remote control lever on equipment in FAST (high speed) position. Loosen control casing clamp screw "B". Move control casing "A" and wire until lever touches tab "C". Tighten casing clamp screw "B". Move remote governor throttle control back to "STOP" position. Lever must make good contact with stop switch, if engine is so equipped.

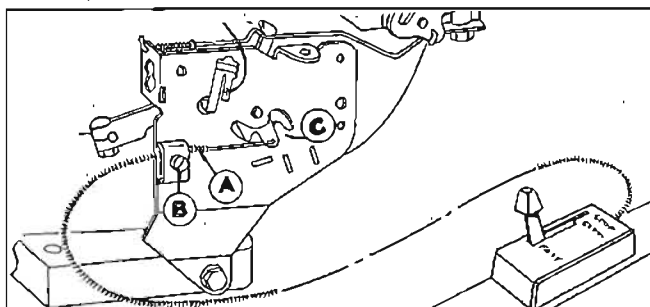

The recommended operating speed range is 1800 to 4000 RPM. The standard speed setting (no load) is 3600 RPM. Idle speed is 1750 RPM.

# GENERAL INFORMATION

These engines are single-cylinder, L-head, air-cooled type

## MODEL SERIES

251400 to 251499

Bore .....	3-7/16"
Stroke .....	2 5/8"
Displacement .....	24.36 cu. in.
Horsepower .....	10 H. P. max @ 3600 RPM
Torque (Ft. Lbs) .....	16.8 max @ 2400 RPM

The horsepower ratings listed above are established in accordance with the Society of Automotive Engineers Test Code-J607. For practical operation, the horsepower loading should not exceed 85% of these ratings. Engine power will decrease 3½% for each 1,000 feet above sea level and 1% for each 10° above 60° F.

In some areas, local law requires the use of a resistor spark plug so as to suppress ignition signals. If an engine was originally equipped with a resistor spark plug, be sure to use the same type of spark plug for replacement.

## TUNE-UP SPECIFICATIONS

	A.C.	Autolite	Champion
Spark Plug Type			
Short Plug	CS-45	A7N	CJ-8
Long Plug	GC-46	A71	J-8
Resistor Short Plug	None	AR7N	RCJ-8
Resistor Long Plug	R-46	AR80	RJ-8
Spark Plug Gap .....			.030"
Ignition Point Gap .....			.020"
Intake Valve Clearance .....			.005" — .007"
Exhaust Valve Clearance .....			.009" — .011"

## STORAGE INSTRUCTIONS

Engines to be stored over 30 days should be completely drained of fuel to prevent gum deposits forming on essential carburetor parts, fuel filter and tank.

- All fuel should be removed from the tank. Run the engine until it stops from lack of fuel. The small amount of fuel that remains in the sump of the tank should then be removed by absorbing it with a clean, dry cloth.
- While engine is still warm, drain oil from crankcase. Refill with fresh oil.
- Remove spark plug, pour one ounce (2 or 3 tablespoons) of engine oil into cylinder and crank slowly to distribute oil. Replace spark plug.
- Clean dirt and chaff from cylinder, cylinder head fins and blower housing.
- Store in a clean, dry area.

BRIGGS & STRATTON ENGINES ARE MADE UNDER ONE OR MORE OF THE FOLLOWING PATENTS:

2,669,322	2,796,453	3,114,851	3,149,618	3,194,224	3,252,449
2,693,789	2,999,491	3,118,433	3,165,094	3,236,937	3,278,439
2,693,791	2,999,562	3,144,097	3,168,936	3,242,741	3,378,099
					3,415,237

DESIGN  
D-191,806 D-196,017 D-197,175 D-213,476  
OTHER PATENTS PENDING